



Mechanical Shaft Seals | Rotary Joints | Components



## ABOUT US

**Mexico Engineering** incorporated in 2004 is engaged in the business of manufacturing, designing, marketing and exporting a wide range of high quality Mechanical Seals and Associated products to cater the growing needs of process industries.

With our genuine quality products, excellent service, consistent performance and competitive prices, **Mexico Engineering** has built up a strong reputation to meet the growing demand of customers over the global market.

**Mexico Engineering** design's and manufacture's seal for rotating equipments including Pumps, Reactor Vessels, Mixers, Compressors, Separators, Steam Turbines and other various applications for Pharmaceuticals, chemicals, petrochemicals, Fertilizers, Refineries, Power Plant, Paper and Pulp as well as other major industries.



## MANUFACTURING FACILITY

**Mexico Engineering** has a in house manufacturing facility with modern precision machineries, instruments and skilled work force with total commitment to meet and fulfil the increasing demands and requirements of our customers.

## QUALITY

**Mexico Engineering** is a quality driven company. Quality ranks high on our priority list for the satisfaction of our customers, We aim to reach the acme of perfection by engineering products that are not only innovative but rich in quality. Our team of experts maintains a strict vigil during the manufacturing process so that the products are flawless.

## AIM

**Mexico Engineering** aims to achieve total customers satisfaction by responding to their needs, offering sealing solution and by providing high standard quality products to their cause of smooth and trouble free operation of their plants and equipments.

## OUR TEAM

Our team comprises of qualified and experienced professional, who continuously work for the development of the company. Apart from this, we have highly dedicated workforce, who are committed towards their work. Our marketing team professionals work in close co-ordination with the clients, to offer the products as per their specifications.

## SERVICE

Round the clock and all over india, Mexico Engineering staff is available to resolve customer's problems. Our engineers have great experience and technical knowledge of mechanical seals, support system and rotating equipments, which enable them to quickly point out the root cause accurately

Series **14V** are single coil spring unbalanced seals designed for dirty media and clogging type application. These seal are not effected by the direction of shaft rotation, as it is driven by lugs. The PTFE double V-Packing's help to get perfect dynamic sealing. These seal are ideal to minimize the stock as the seal components are interchangeable.

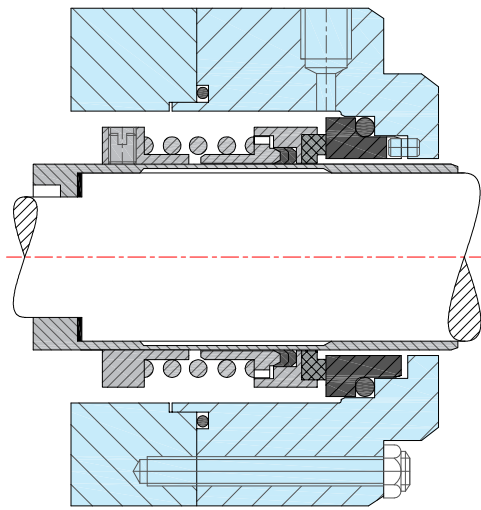

**Seal features**  
 Single seal  
 Inside mounted  
 Unbalanced

**Operating limit**

Seal size : 14 mm to 90mm  
 Pressure : 10 kg/cm<sup>2</sup>  
 Temp : -30°C... to 150°C  
 Speed : up to 20 m/s

**Application**

Petrochemicals  
 General Chemical  
 Light hydrocarbons  
 Refineries

**Material**

Seal face : Carbon, ceramic, silicon tungsten carbide,  
 Secondary sealing : Viton, GFT, PTFE, Aflas  
 Metal parts : SS316 , Hastelloy c, Alloy-20

Series **14U** are single spring seals. These seals are easy to install and operate for different application being used in various industries. These seals are compact in design for handling liquids of varying contamination including Slurries Sludge, sewage, Viscous and crystallizing Solution. These Seals are designed in both balanced and unbalanced version based on pressure parameters. Spring clogging does not occur in single spring seals.

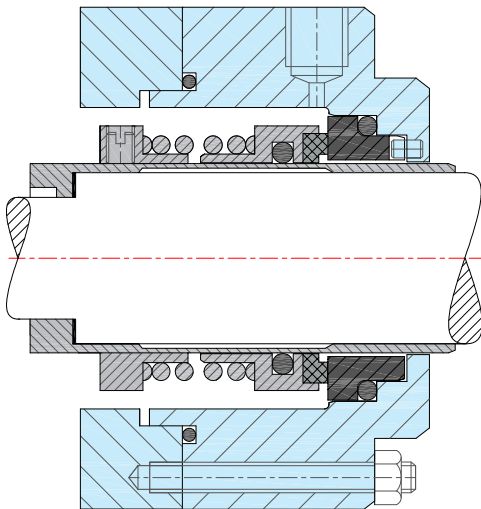

**Seal features**  
 Single seal  
 Inside mounted  
 Unbalanced  
 Depended on direction of rotation

**Operating limit**

Seal size : 14 mm to 90mm  
 Pressure : 10 kg/cm<sup>2</sup>  
 Temp : -30°C... to 150°C  
 Speed : up to 20 m/s

**Application**

Petrochemicals  
 General Chemical  
 Light hydrocarbons

**Material**

Seal face : Carbon, ceramic, silicon tungsten carbide,  
 Secondary sealing : Viton, PTFE, Aflas  
 Metal parts : SS316 , Hastelloy c, Alloy-20

Series **12W** are general purpose multi coil spring unbalanced seals. These seals are provided with O-Ring Sealing device due to its compact design and narrow cross section, these seals occupies very less area in stuffing box. Lower spring loads provided through wedge or O-Ring minimizes shaft fretting. One can easily assemble and dismantle these seals through the circlip provided. These seals can be changed to balance version of its type merely by changing the carbon face only & can be provided with single, double or tandem arrangement with external seal support system and devices.

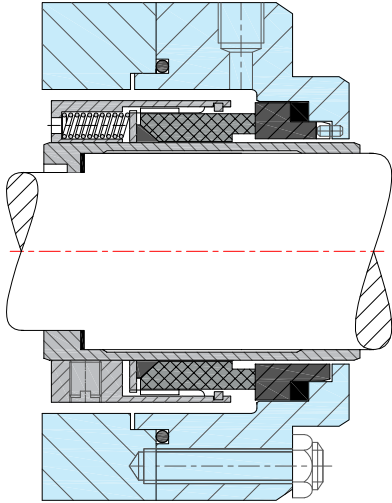

### Seal features

Single seal  
Inside mounted  
Unbalanced

### Operating limit

Seal size : 14 mm to 150mm  
Pressure : 10 kg/cm<sup>2</sup>  
Temp : -30°C.... To +200°C  
Speed : up to 20 m/s

### Application

Petrochemicals  
General Chemical  
Petroleum refinery  
Light hydrocarbons

### Material

Seal face : Carbon, ceramic, silicon tungsten carbide,  
Secondary sealing : Viton, GFT, PTFE, Aflas  
Metal parts : SS316 , Hastelloy c , Alloy-20

Series **12RV** seals are multiple spring seals. These seals are available in both balance and unbalance configuration. The rotary unit of these seals are comprises three pieces viz., seal ring, multiple springs & compression ring. The efficient cleaning of accumulations around spring when used in dirty fluids (normally the special feature of the single coil spring design) is achieved by the exposed. These seals are not affected by the direction of shaft rotation.

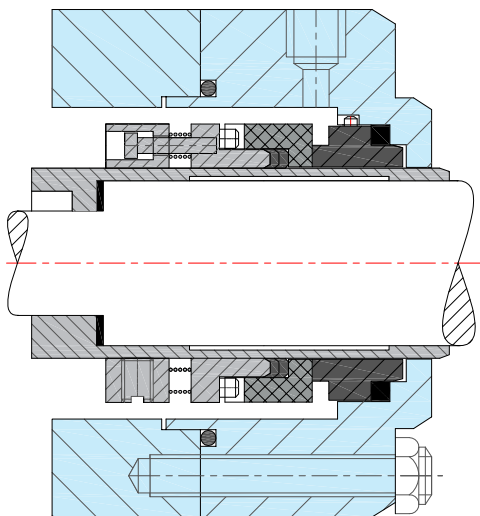

### Seal features

Single seal  
Inside mounted  
Unbalanced  
Interchangeable seal face

### Operating limit

Seal size : 14 mm to 120mm  
Pressure : 10 kg/cm<sup>2</sup>  
Temp : -30°C.... To +200°C  
Speed : up to 20 m/s

### Application

Petrochemicals  
General chemical  
Petroleum refinery  
Light hydrocarbons

### Material

Seal face : Carbon, ceramic, silicon, tungsten carbide  
Secondary sealing : Viton, GFT, PTFE, Aflas, TTV  
Material : SS 316 , Hastelloy c , Alloy-20

Series **13M** are single wave spring seals for most general application, being used in industries like Paper and Pulp, Sugars, Sewage, Polymer, Rubber etc. Its compact design with reduced axial length is the major advantage of using single wave spring seals. These seal are designed to handle dirty and slurry application as spring clogging does not occur.

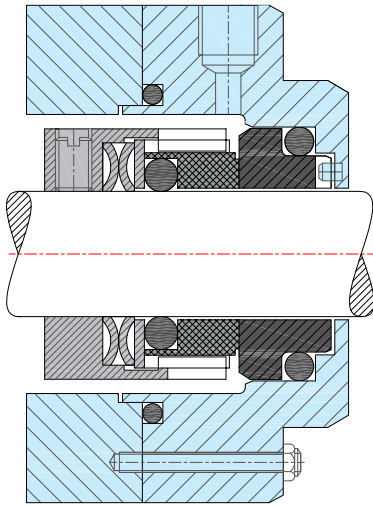

### Seal features

Single seal  
Inside mounted  
Unbalanced  
Wave spring loaded seal

### Operating limit

Seal size : 18 mm to 100mm  
Pressure : 8 kg/cm<sup>2</sup>  
Temp : -20°C.... To +180°C  
Speed : up to 20 m/s

### Application

Corrosive chemical  
Hydrocarbon  
General and light chemical

### Material

Seal face : Carbon, Ceramic, Silicon, Tungsten carbide  
Secondary sealing : Viton, GFT, PTFE, Aflas, TTV  
Material : SS 316, Hastelloy c, Alloy-20

Series **12B** are multi coil spring balanced seal generally used for high pressure sealing purpose in industries like petrochemicals, refineries, fertilizers. These seal occupies lesser space in stuffing box due to its compact radial and axial dimensions. These seals can be provided with single, double or tandem arrangement with external seal support system and devices.

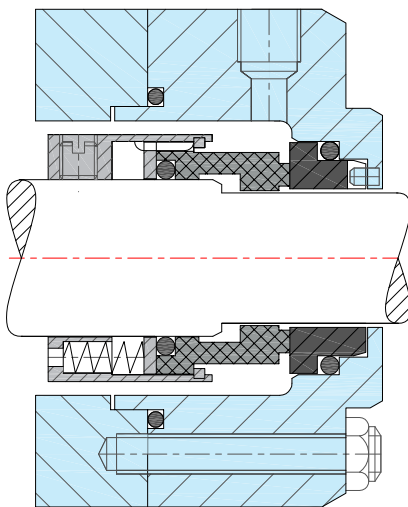

### Seal features

Single seal  
Inside mounted  
Balanced

### Operating limit

Seal size : 19 mm to 100mm  
Pressure : 15 kg/cm<sup>2</sup>  
Temp : -20°C.... To +200°C  
Speed : up to 20 m/s

### Application

Acids Alkalis  
Petrochemicals  
General chemical  
Petroleum refinery

### Material

Seal face : Carbon, ceramic, silicon tungstune carbide,  
Secondary sealing : Viton, GFT, PTFE, aflas, TTV  
Metal Components : SS-316/Hast-C,Alloy-20

Series **12B2** are multi spring reverse balanced seal, which are externally mounted. These seals are designed to handle corrosive or abrasive media, as the metal components of these seal do not come in contact with the media to be sealed. Due to its compact design neither radial nor axial extra space is required for installation. These seal can also be installed in double back to back arrangement as internal seal. Though the pressure of the barrier fluid goes down this seal will not allow the process fluid to get mix with barrier fluid, hence it is called a reverse balanced seal.

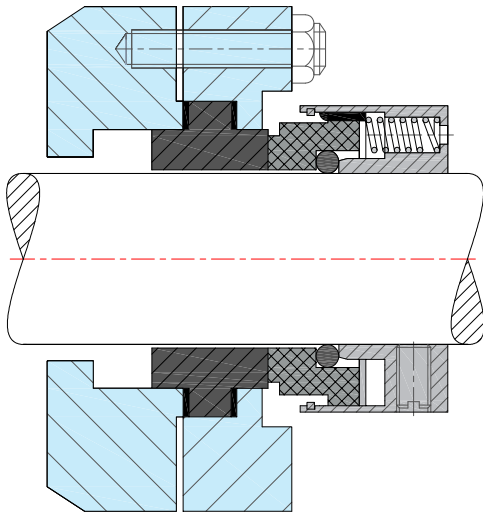

### Operating limit

Seal size : 19 mm to 100mm  
 Pressure : 15 kg/cm<sup>2</sup>  
 Temp : -20°C... to 180°C  
 Speed : up to 20m/s

### Application

Corrosive chemical  
 Hydrocarbon  
 General and light chemical

### Seal features

Single seal  
 Outside mounted  
 Balanced

### Material

Seal face : Carbon, Ceramic, Silicon, TC  
 Secondary sealing : Viton, GFT, PTFE, TTV  
 Metal Components : SS-316/Hast-C/Alloy-20

Series **14W** are single coil spring seal designed to handle dirty media and clogging type application. These seal can be easily installed and removed as all the components are held together by a snap ring. These seals are independent on direction of rotation as the torque transmission is done through drive lugs, as the part are interchangeable can be converted into **14W-O** by changing the seal ring and the secondary seal.

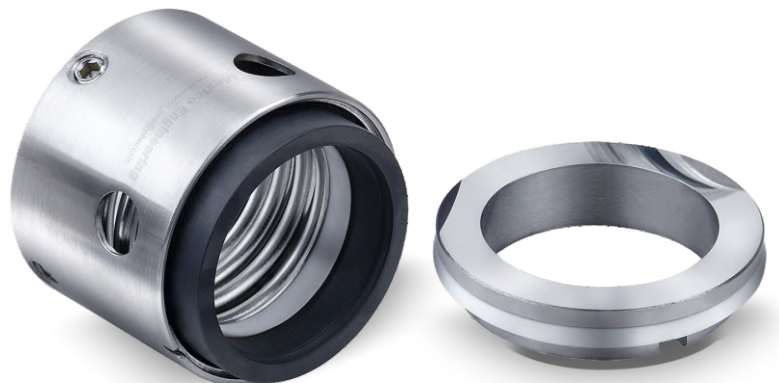
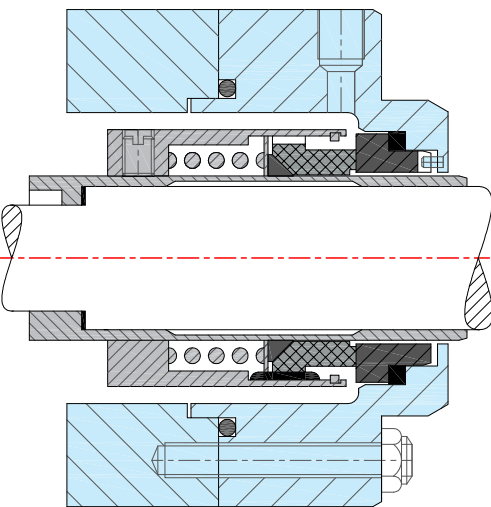

### Operating limit

Seal size : 14 mm to 100mm  
 Pressure : 10 kg/cm<sup>2</sup>  
 Temp : -30°C... To +200°C  
 Speed : up to 20 m/s

### Application

Fertilizers plant  
 General chemical pump  
 Petroleum Refinery Light hydrocarbons

### Seal features

Single seal  
 Inside mounted  
 Unbalanced/ Balance

### Material

Seal face : Carbon, Ceramic, Silicon Tungstun Carbide,  
 Secondary sealing : Viton, GFT, PTFE, Aflas, Kalrez  
 Material : SS 316 , Hastolloy c , Alloy-20

Series **16U** are single coil conical spring , unbalanced seal with O-Ring as a secondary sealing device. These seal are dependent on the direction of rotation, as the torque transmission is done by single conical spring. Direction of rotation is seen from the drive end of the shaft. Right handed springs are provided for clockwise rotating shaft, and left handed spring are provided for anti clockwise rotating shafts. These seal can be easily assembled and dismantled as it consists very few parts. Due to its compact design no axial or radial extra space is required for installation. These seals are designed to handle contaminated liquids, hence spring clogging does not occur.

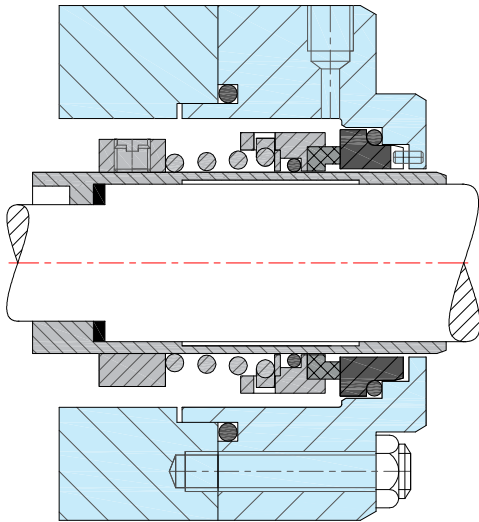

**Seal features**

- Single seal
- Inside mounted
- Unbalanced
- Depended on direction of rotation

**Material**

- Seal face : Carbon, Ceramic, Silicon, Tungsten Carbide
- Secondary sealing : Viton, GFT, PTFE, Aflas
- Metal Components : SS-316/Hast-C/Alloy-20

**Operating limit**

- Seal size : 14 mm to 120mm
- Pressure : 10 kg/cm<sup>2</sup>
- Temp : -20c.... to 180°c
- Speed : up to 15 m/s

**Application**

- Water pump circulation
- Pump chemical process pump
- Sewage & submersible pump

## Capsulated Multi Spring Seal

Series **12HS** is a multiple springs unit specially developed for slurry application. The springs are protected from media by means of dynamic O-ring. Although being a balance seal no need to maintain step sleeve. The sleeve of unbalanced seal can be used for this seal series without modification. Torque transmission to the seal ring is given by strong multiple drive pins / lugs.

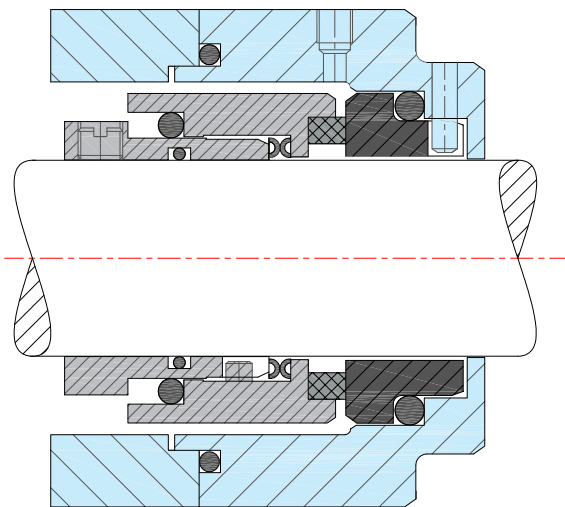

**Seal features**

- Single seal
- Inside mounted
- Balanced
- Capsulated Spring
- Independed on direction of rotation

**Material**

- Seal face : Carbon, ceramic, silicon tungstune carbide,
- Secondary sealing : Viton, PTFE, aflas, TTV
- Metal Components : SS-316/Hast-C,Alloy-20

**Operating limit**

- Seal size : 20 mm to 100mm
- Pressure : 10 kg/cm<sup>2</sup>
- Temp : -20°C.... To +140°C
- Speed : up to 20 m/s

**Application**

- General Chemical
- Food Industries
- Media Containing Slurry
- Mining Industry



Series **12T/12TB** are Teflon Bellow Seals designed to handle highly corrosive chemical, such as concentrated acids, caustic, strong oxidizing and reducing agents, and chemically active organic components. These seals are externally mounted with easy installation procedure. These seal can be offered in composite or replaceable face design, replaceable face version give flexibility to select face material for the media to be sealed. All the components which come in contact with media to be sealed are made of chemically inert material, hence it is effective and reliable to perform against extreme corrosive media. Metallic Components such as clamping ring and spring does not come in contact with the media to be sealed.

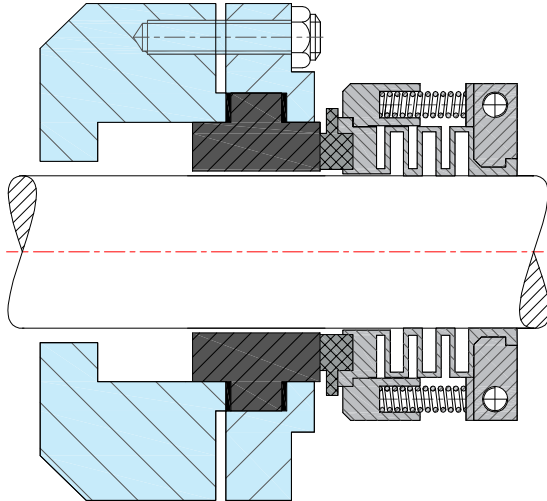

#### Seal features

Single seal  
Outside mounted  
Unbalanced  
Teflon bellow seal with replaceable Sic face

#### Material

Seal face : Carbon, Ceramic, Silicon, GFT  
Secondary sealing : PTFE Bellow  
Metal components : SS 316, Hastolloy c, Alloy-20

#### Operating limit

Seal size : 18 mm to 100mm  
Pressure : 06 kg/cm<sup>2</sup>  
Temp : -20°C.... To +110°C  
Speed : up to 20 m/s

#### Application

Extremely corrosive service & acids  
Alkalis

Series **22G** Seals are welded metal bellow seal being used in chemical ,petrochemical refineries for high temperature application. Use of spring is eliminated in these seals, because of incorporated flexibility in the metallic bellow. These Seals are non-pusher and balanced in nature having self-cleaning action. These seals do not required secondary sealing devices like o-rings or wedges, hence shaft fretting in avoided.

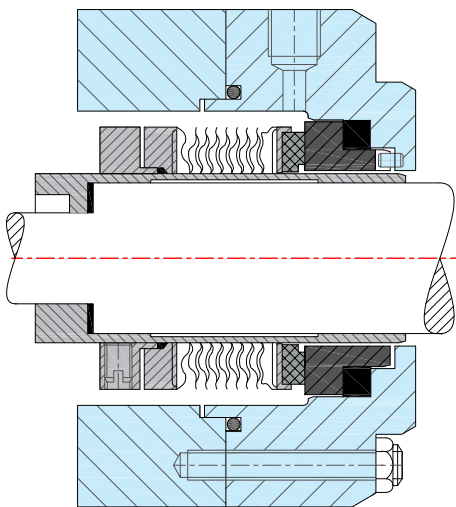

#### Seal features

Single seal  
Inside mounted, Unbalanced  
Depended on direction of rotation  
Welded metal bellow

#### Material

Seal face : Carbon, Silicon, Tungsten Carbide  
Secondary sealing : Grafoil,  
Welded bellow : SS 316, AM-30, Hastelloy-c,  
Titanium, Alloy-20

#### Operating limit

Seal size : 20 mm to 90 mm  
Pressure : 12 kg/cm<sup>2</sup>  
Temp : -20°C.... To 400°C  
Speed : up to 20 m/s

#### Application

Petrochemicals  
Petroleum refinery  
Oil refinery  
Nuclear plant





Series **22U** are welded metal bellow seals designed to handle moderate temperature applications, corrosive as well as abrasive and viscous media. These seals are independent of direction of rotation and are widely used in refineries, petrochemicals and chemical industries. The possibility of seal hang-up is prevented as there is no dynamic 'o' ring used in this type of seal, hence static O-ring is used as a secondary member.

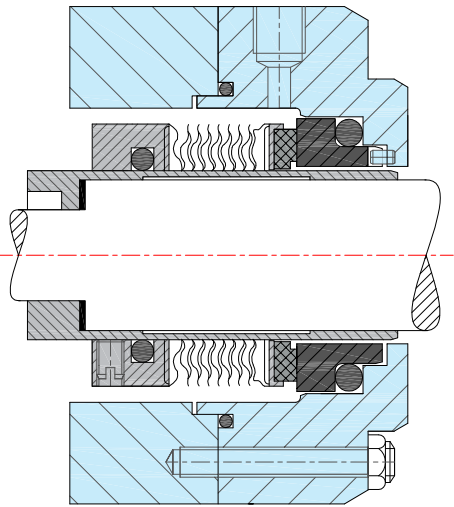

### Seal features

- Single seal
- Inside mounted
- Unbalanced
- Welded metal bellow

### Material

- Seal face : Carbon, Silicon, Tungsten Carbide
- Secondary sealing : Viton, PTFE, Kalrez,
- Metal components : SS 316, Am 350, Hastelloy c, Alloy-20

### Operating limit

- Seal size : 25 mm to 100mm
- Pressure : 12 kg/cm<sup>2</sup>
- Temp : -20°C.... To +250°C
- Speed : up to 20 m/s

### Application

Petrochemical refinery, oil refinery

Series **25R** are single coil spring seals with elastomeric bellow used for general, non-critical and light applications like water, oil, etc. These seals are not effected with the direction of rotation, as the acting torque is not transmitted through the coil spring. Single coil spring are provided for non-clogging, self-cleaning operation, and elastomeric bellow for self-alignment in case of radial and axial play in shaft, notches provided on seal faces and retainer gives extra positive drive.

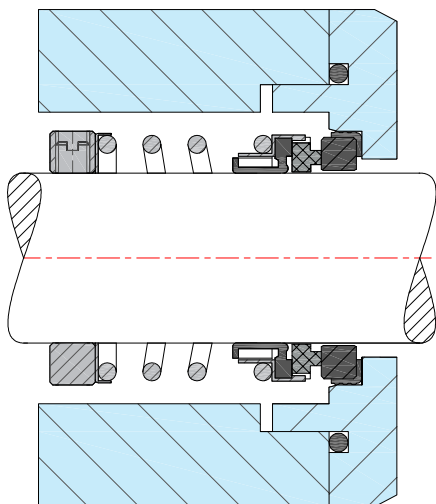

### Seal features

- Single seal
- Inside mounted
- Unbalanced
- Elastomer bellow seal

### Material

- Seal face : Carbon, Ceramic, Silicon Tungsten Carbide, Chrome cast
- Secondary sealing : Viton, Nitrile, Neoprene

### Operating limit

- Seal size : 20 mm to 90 mm
- Pressure : 10 kg/cm<sup>2</sup>
- Temp : -20°C.... To 150°C
- Speed : up to 20 m/s

### Application

Water pump, Gear pump,  
Refrigeration compressor  
Fuel injection pumps  
Submersible pumps, Sewage pump



Series **25M** are single coil spring elastomer bellow seals, being designed for general sealing purpose including easy installation of the seal. These seals have a unique rubber bellow secondary seal with self-aligning features which compensates abnormal shaft end play and run-out to provide service life. Shaft / sleeve fretting is avoided due to elastomeric bellow, the seal faces are driven through coil spring and spring holder.

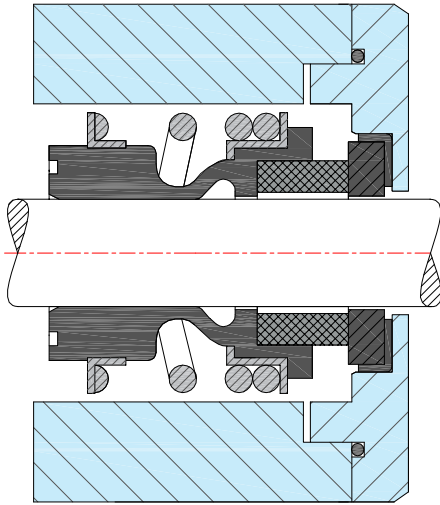

#### Seal features

Single seal  
Inside mounted  
Unbalanced  
Depended on direction of rotation  
Elastomer bellow seal

#### Material

Seal face : Carbon, Ceramic, Silicon Tungsten Carbide  
Secondary sealing : Viton, Nitrile, Neoprene, EPDM

#### Operating limit

Seal size : 12 mm to 100mm  
Pressure : 10 kg/cm<sup>2</sup>  
Temp : -20°C.... to + 160°C  
Speed : up to 20 m/s

#### Application

Waste water pump  
Submersible pump  
Sewage pump

Series **25J** are single coil spring elastomer bellow seals , being designed for general sealing purpose including easy installation of the seal. These seals have a unique rubber bellow secondary seal with self aligning features which compensates abnormal shaft end play and run-out to provide service life. Shaft / sleeve fretting is avoided due to elastomeric bellow notches provided on seal faces and retainer gives extra positive drive.

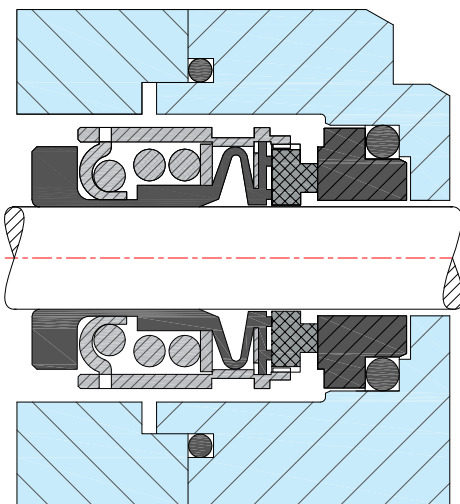

#### Seal features

Single Seal  
Inside mounted  
Unbalanced  
Depended on direction of rotation  
Elastomer Bellow Seal

#### Material

Seal face : Carbon, Ceramic, Silicon, TC  
Secondary sealing : Viton, Neoprene

#### Operating limit

Seal size : 20 mm to 60 mm  
Pressure : 8 kg/cm<sup>2</sup>  
Temp : -20°C.... to + 120°C  
Speed : up to 25 m/s

#### Application

Water Pump  
Submersible Pump  
Sewage Pump  
Dyeing Machine



Series **14SC** are single acting pre-assembled cartridge mechanical seals, which could be directly installed without any dimensional adjustment during installation. These cartridge balanced seals are independent of direction of rotation being designed to handle slurries, sludge, thick syrup and polymerising fluids. The spring provided in the cartridge construction are being isolated from the fluid enhancing the seal life.

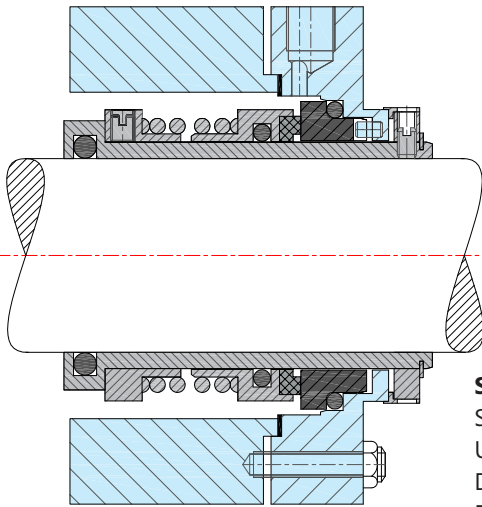

**Seal features**

- Single seal, Inside mounted
- Unbalanced
- Dependent on direction of rotation
- Easy Installation, Field repairable
- Interchangeable mating rings & seal ring

**Operating limit**

- Seal size : 20 mm to 100mm
- Pressure : 10kg/cm<sup>2</sup>
- Temp : -20°C.... to 150°C
- Speed : Up to 20 m/s

**Application**

- General Chemicals
- Food industries

**Material**

- Seal face : Carbon, Ceramic, Silicon, Tungsten Carbide
- Secondary sealing : Viton, PTFE, GFT

Series **14DC** are double acting cartridge mechanical seals having integral sleeve and gland plate. These multi spring design seal are pre-assembled, which could be directly installed without any dimensional adjustment during installation. These seals are balanced, independent of direction of rotation and are offered in back to back and tandem arrangements as per API plan-53

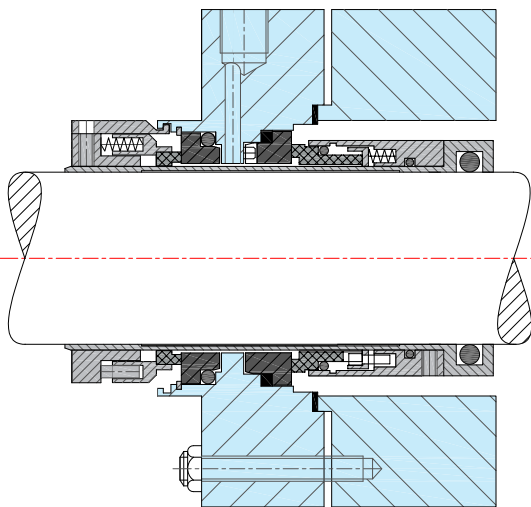

**Seal features**

- Double seal, Cartridge unit
- Inside Mounted, Balanced
- Easy Installation, Field repairable
- Interchangeable mating rings & seal ring

**Operating limit**

- Seal size : 20 mm to 100mm
- Pressure : 10kg/cm<sup>2</sup>
- Temp : -20°C.... to 180°C
- Speed : up to 20 m/s

**Application**

- Pulp & paper industries
- Chemical industries Slurry Pump
- Sludge Pump

**Material**

- Seal face : Carbon, Ceramic, Silicon, Tungsten Carbide
- Secondary sealing : Viton, PTFE, GFT, Kalrez, Aflas
- Metal Components : SS 316 / Hastelloy c / Alloy -20

Series **12SC/HP** are high pressure cartridge seal designed for high pressure applications, like hot water, crude oil, light hydrocarbons. These seal are provided with single, double or tandem arrangement, which are widely used for applications such as boiler feed water pumps, main crude oil transportation pump and multi-phase pumps. Its sturdy designed and drive arrangement makes the seal suitable for high pressure applications. Multiple spring designed provides uniform face loading.

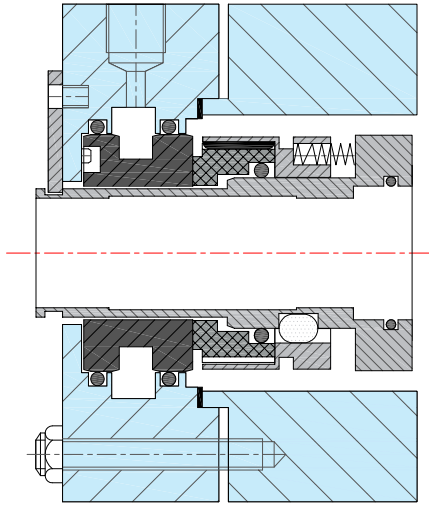

**Seal features**

- Single seal
- Inside mounted
- Balanced
- Independed on direction of rotation

**Operating limit**

- Seal size : 25 mm to 100mm
- Pressure : 30kg/cm<sup>2</sup>
- Temp : -30°C.... to 280°C
- Speed : up to 20 m/s

**Application**

- Boiler feed hot water pump
- Light Hydrocarbons



**Material**

- Seal face : Carbon, Ceramic, Silicon, Tungsten Carbide
- Secondary sealing : Viton, Kalrez, Aflas
- Metal Components : SS 316 / Hastelloy c / Alloy -20

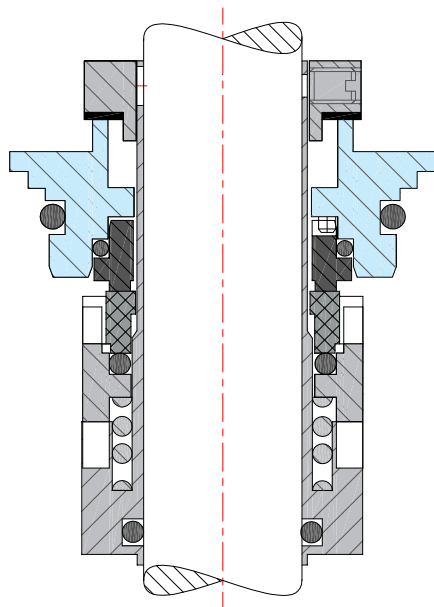

**Seal features**

- Single seal
- Inside mounted
- Unbalanced
- Cartridge Unit
- Easy Installation
- Interchangeable mating rings & seal ring

**Operating limit**

- Seal size : 12 mm, 16mm & 22mm
- Pressure : 6kg/cm<sup>2</sup>
- Temp : -20°C.... to 180°C
- Speed : Up to 25 m/s

**Application**

- Water
- Food industries
- Solvent
- RO Plant



**Material**

- Seal face : Silicon, Tungsten Carbide
- Secondary sealing : Viton, EPDM, Aflas
- Metal Components : SS 316



Series **12DS** is a single acting, multi spring, externally mounted reverse balanced dry seal with O-ring as a secondary sealing member for glass lined, ss mixers, agitators and reactor vessels. These seals are basically used on top entry agitators for food and pharmaceutical industries where contamination of the media with any other liquid inside the agitator is not permissible. These seals do not require any external lubrication to the seal faces, hence these seals are known as dry running seals.

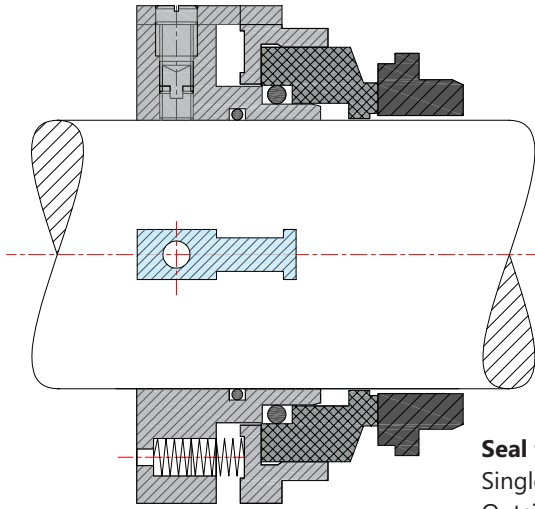

### Seal features

- Single seal
- Outside mounted
- Balanced
- Dry Running seal

### Operating limit

- Seal size : 25 mm to 150mm
- Pressure : 8 kg/cm<sup>2</sup>
- Temp : -20°C... to 120°C
- Speed : 200 rpm

### Application

- Corrosive chemicals
- General light chemicals
- Food Product
- Pharmaceutical products

### Material

- Seal face : Carbon, Ceramic, Silicon, Tungsten carbide
- Secondary sealing : Viton, GFT, PTFE, TTV
- Metal components : SS316 / Hastolloy c / Alloy -20



Series **12SR** are factory assembled single agitator seals which are dynamically tested being used for steel, glass lined, ss mixers, agitators and reactor vessels. Clean soft water is mainly preferred because of its good heat transfer qualities, as these seals are used with non pressurised barrier fluid. To ensure cool running these seals can be supplied with cooling water jacket.

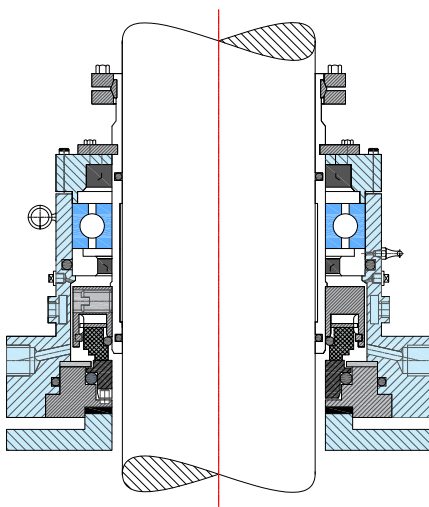

### Seal features

- Single seal, Cartridge unit
- Inside mounted, Balanced
- Easy Installation, Field repairable
- Interchangeable mating rings & seal ring

### Operating limit

- Seal size : 20 mm to 140mm
- Pressure : Under Vacuum to 8 kg/cm<sup>2</sup>
- Temp : -20°C... to 150°C
- Speed : up to 25 m/s

### Application

- Pharma industries
- Chemical industries
- Foods industries

### Material

- Seal face : Carbon, Ceramic, Silicon, Tungsten Carbide
- Secondary sealing : Viton, PTFE, GFT, FEP, TTV
- Metal Components : SS 316 / Hastelloy c / Alloy -20





Series **12DR** are pre-assembled double mechanical cartridge seals, used for glass lined, steel, agitators, mixers and vessels. The construction of seal slightly change for top entry, side entry and bottom entry vessels. The design incorporates bearing located very close to the seal. These seals are supplied with cooling jacket, to maintain cool environment around the seal. Large clearance between shaft / sleeve and mating ring permits higher deflection of the shaft.

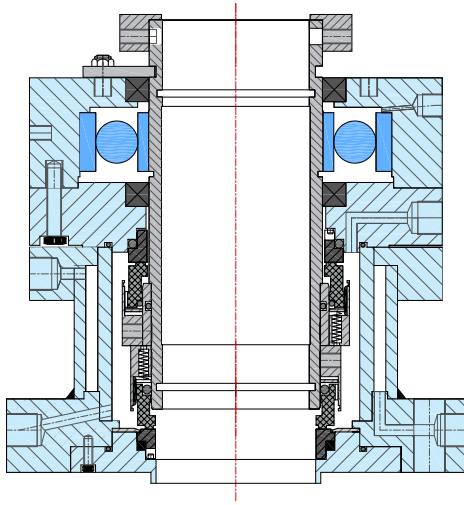

### Seal features

- Double back to back seal
- Cartridge type seal
- Unbalanced
- Operated with pressurized barrier fluid

### Operating limit

- Seal size : 25 mm to 140mm
- Pressure : under vacuum to 20 kg
- Temp : ambt..... to 200°C
- Speed : 250 rpm

### Application

- Paper Industries
- Pharmaceutical industries
- General chemicals and its vapours
- Petrochemical and its vapours
- Light hydrocarbon and its vapours

### Material

- Seal face : Carbon, Silicon carbide, Ceramic, Tungsten carbide
- Secondary sealing : Viton, GFT, PTFE, TTV, FEP
- Metal components : SS 316 , Hastelloy c, Alloy-20

Series **12WS** seals employ dual balanced multispring seals with dynamic 'O'-ring of bigger cross section for higher reliability. Seal ring is of heavy duty design and stationary face is hydraulically balanced to avoid accidental pop-up.

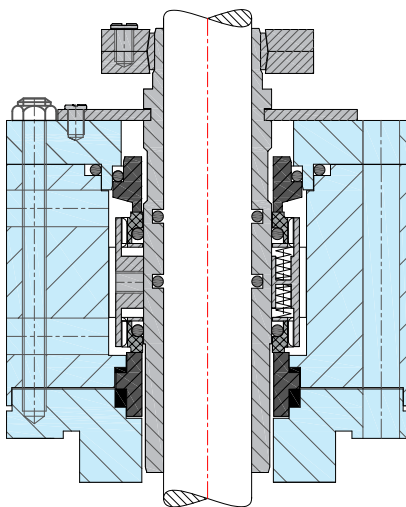

### Seal features

- Double back to back seal
- Cartridge type seal
- Unbalanced

### Operating limit

- Seal size : 25 mm to 120mm
- Pressure : under vacuum to 15 kg
- Temp : ambt..... to 200°C
- Speed : 250 rpm

### Application

- Paper Industries
- Pharmaceutical Industries
- General chemicals and its vapours

### Material

- Seal face : Carbon, Silicon Carbide, Ceramic, TC
- Secondary sealing : Viton, GFT, PTFE, TTV, FEP
- Metal Components : SS 316, Hastelloy-c, Alloy-20



# Thermosyphon

Series MTS-10 is a thermosyphon system, which is basically used as a storage and pressurising unit. Using thermosyphon system it is possible to supply barrier fluid to double mechanical seal in back to back or tandem arrangement. The pressure of barrier fluid is higher than the pressure of the fluid to be sealed. The temperature of the barrier fluid from seal to thermosyphon is controlled by the cooling coil inside the shell.

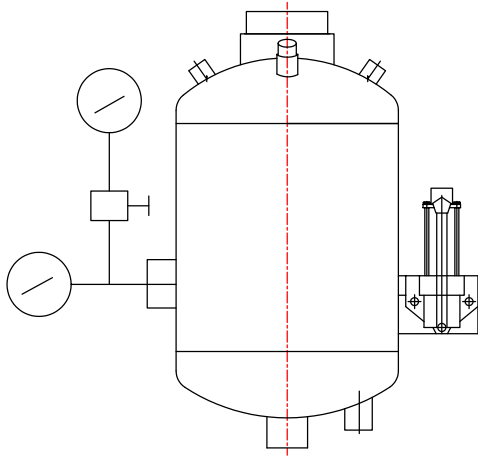

### Material

- Contents of tank : 10 litres
- Operating Volume : 2 litres
- Operating Pressure : 20 kg/cm<sup>2</sup>
- Working Temperature : -60°C to +200°C
- Hydraulic test pressure – 15 bar
- Cooling water inlet- ½" npt
- Cooling water outlet ½" npt
- Barrier fluid inlet – ½" npt
- Barrier fluid outlet- ½" npt
- Drain- ½" npt

### Metal Parts

- Thermosyphon shell : Carbon steel / SS 304 / SS 316
- Cooling coil : SS 304 / SS 316
- Empty weight : 34 kg (Approx)

# Rotary Joint (SERIES - MRJ111)

### Features

The housing made with G.M. / Brass, the rest of metallic components are made with S.S.

### Size

3/8" BSP to 4" BSP

### Threaded Rotor :

As Per Iso 228 / Npt / Metric  
#optional : Quick Release Nipple [flanged End]

### Body :

Radial or Axial R.H. FEMALE THREAD AS PER ISO 228 OR NPT

### Temperature (max) :

- Water : 95°C
- Thermic Fluid : 250°C
- Steam : 150°C

### PRESSURE (Max) :

- Water : 10 Kg
- Thermic Fluid : 10 Kg
- Steam : 10 Kg

### SPEED (Max) :

- Size : 1/2" - 3/4" - 1440 RPM
- Size : 1" - 2" - 1000 RPM



### Material

- Seal face : Tungsten Carbide, Silicon Carbide, Carbon
- Secondary sealing : Viton, Nitrile, PTFE, Silicon, Kalrez



**Office & Works**

Gala No- AF-17 & AF-08, Saraf Kaskar Ind. Est.,  
S.V. Road ,Oshiwara,Jogeshwari (West),  
Mumbai - 400 102. INDIA.

Tel. : 022-26771386

Telefax : 022-26771387

Email : [info@mexicoengineering.in](mailto:info@mexicoengineering.in)

Web : [www.mexicoengineering.in](http://www.mexicoengineering.in)

